

## Instruction Sheet

Follow these instructions to install a solid shortening heater kit 8263782 in 2-Vat FQE30 3000 & FQE30-T fryers.

1. Disconnect power cord from power source before removing any panels from the equipment. Remove the fryer from the hood to gain access to the front and back of the unit.
2. Remove lower back. It is recommended to also remove doors and cabinet sides for ease of access.
3. Locate and remove ATO/FIB box cover and carefully disconnect wiring from ATO Pump (Figures 1 & 2).
4. Locate and remove splash guard from bottom rear of system (Fig 3).
5. Disconnect ATO flex line from ATO check valve at the return manifold (Fig 4).
6. Remove check valve assembly from the oil manifold and replace with a plug (Fig 5).

Continued on the next page.

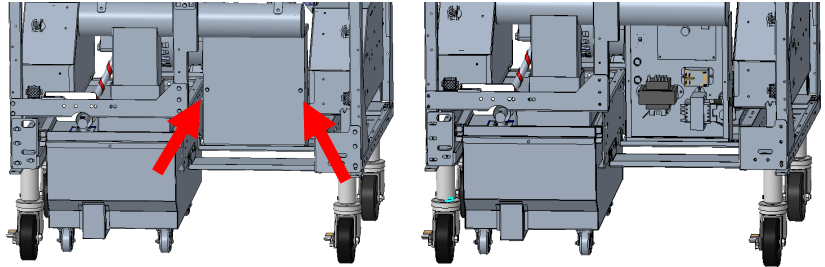

Fig 1

Fig 2

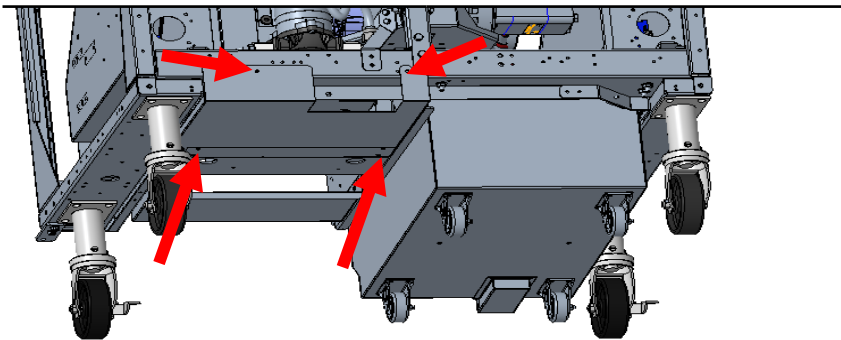

Fig 3

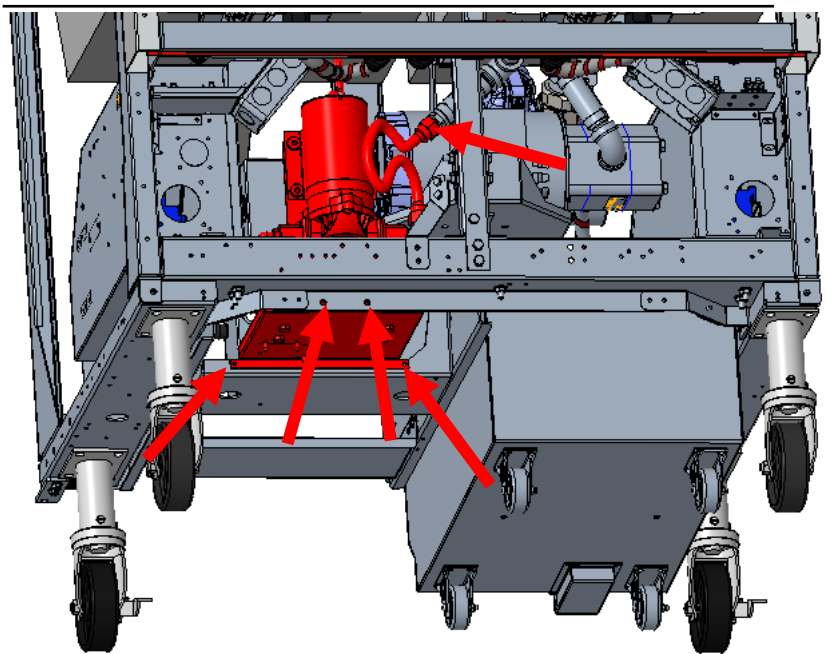

Fig 4

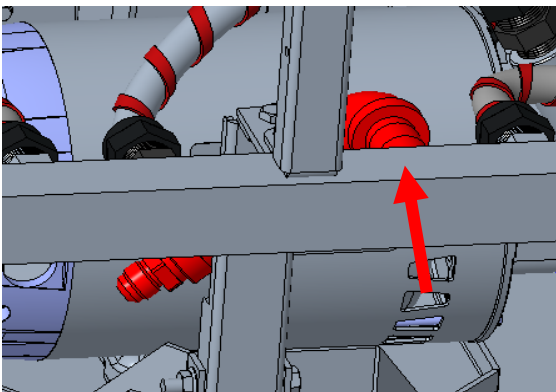

Fig 5

**Continued from page 1**

7. Reinstall ATO box cover from step 3, then remove the wire shield cover from the rear of the box on 3000 fryers (Fig 6). **Skip to step 9 for Touch Screen fryers.**
8. **Non-Touch screen fryers:** Disconnect the ATO probe connections from the top row of the ATO board, This will be the 4 pin connections, and replace with resistor jumpers from the kit. Reinstall shield cover from step 7.
9. Remove the controller from the far left control box. Using the wiring diagram on the last page, feed the 1080490 harness through the rear of the far left control box. Attach the harness to T1 & T2 and allow the C2 connector to remain on rear. Attach the other end of the connector from the heater strips to the C2 connector.
10. Mount handy boxes in location shown on rear of contactor boxes above the power cords (Figure 7).
11. Using one of the 36-inch heaters from the kit and a length of foil tape, add heater to bottom side of manifold, wrapping extra length around the ends and over the top securing in place with foil tape. (Figure 7).

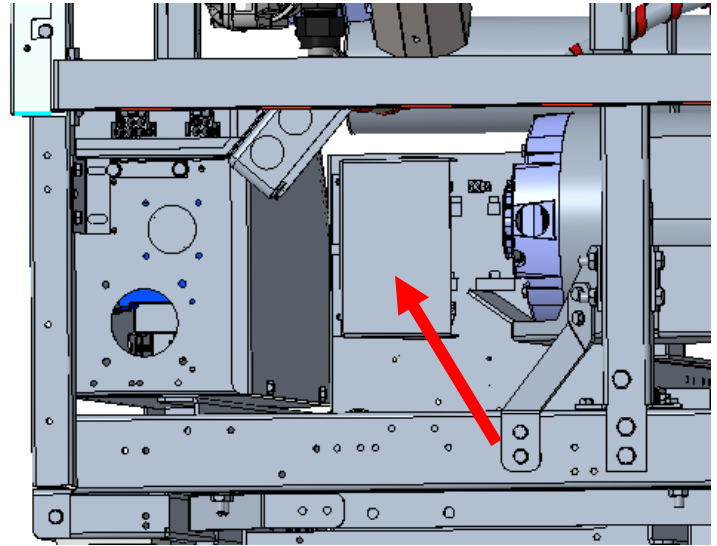

Fig 6

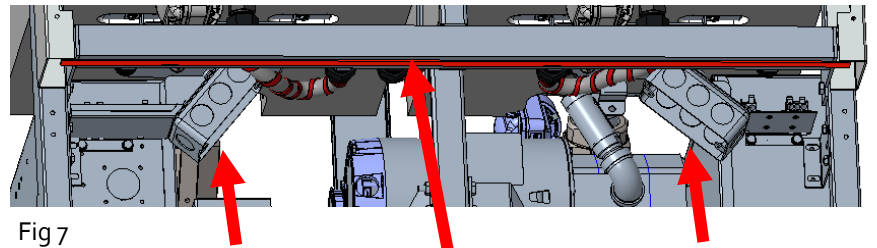

Fig 7

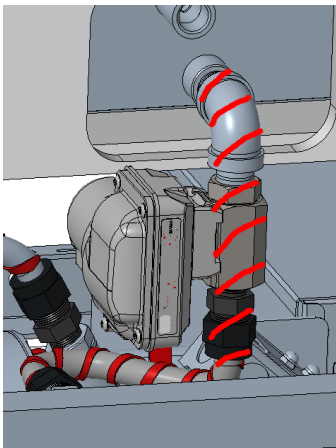

Fig 9

fold, wrapping extra length around the ends and over the top securing in place with foil tape. (Figure 7).

**Continued on the next page.**

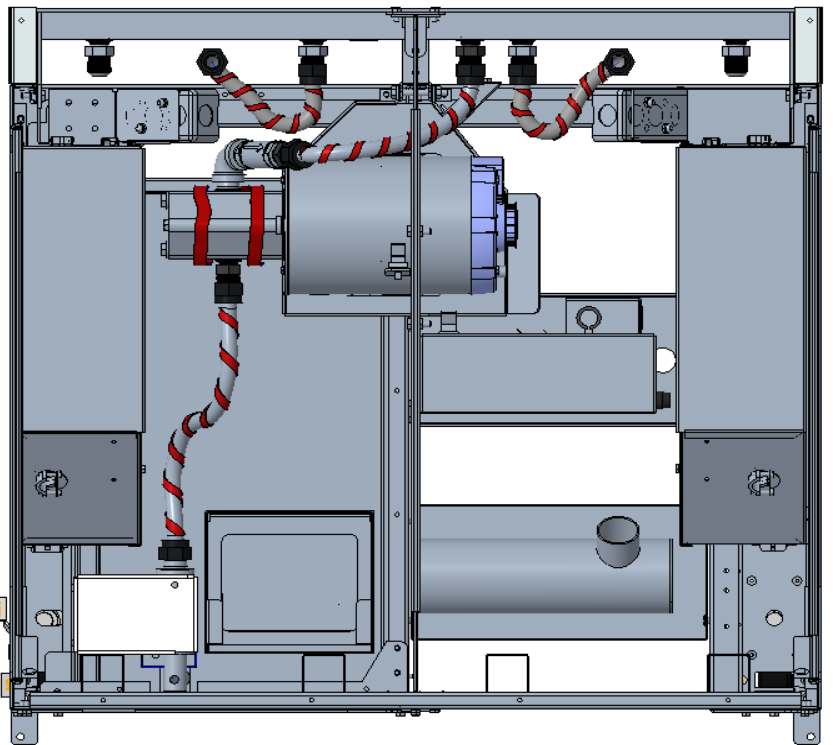

Fig 8

## Continued from page 2

12. Wrap all flex lines and filter pump using foil tape to retain tightly around oil line. While it may not be shown well in illustration, ALL check valves and return valve bodies must also be covered in heater strips (Figures 8 & 9).
13. Reinstall splash guard from (Figure 3).

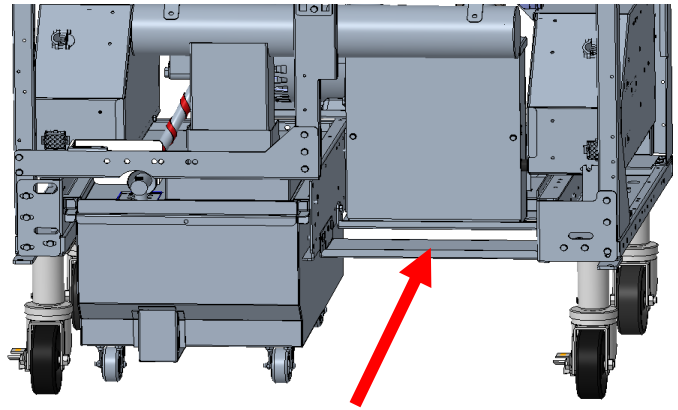

Fig 10

### Using Wago Connectors

Wago connectors allow stripped wires (3mm) to be cleanly connected. They are easy to use:

1. Lift completely the orange lever. It will stay upright.
2. Insert stripped wires.
3. Close orange levers.







14. Remove JIB cradle and install factory shipping brace if available (Figure 10).
15. Route all wires toward handy boxes and cover wires in sleeving.
16. Use Wago terminal blocks to wire up heaters according to diagram.
17. When all heater tapes have been attached and connected, position the fryer near the hood, apply power and test to ensure the heater tapes are functioning.
18. Replace back on fryer. This completes the installation for Non-touch screen fryers. For Touch screen fryers, continue to step 19.

**Continued on the next page.**

**Continued from page 3**

**Steps below are for Touch Screen Fryers only**

19. Once fryer has powered up, wait one (1) additional minute with the controller OFF and press the **HOME** button on the left controller. 
20. Press the **SETTINGS** button. 
21. Press the **SERVICE** button. 
22. Enter **3000**.
23. Press the v (check) button.
24. Press the down arrow button two times.
25. Press **AUTO TOP OFF VAT**.
26. Press **OFF**.
27. Press the **HOME** button to exit. 
28. Repeat steps 19—27 on each controller.
29. Press and HOLD the momentary reset switch located close to the USB port. Ensure the switch is pressed and held for **ONE** (1) minute.

**Continued on the next page.**

